



Range of in-line rectangular duct fan, specially designed for the extraction of potentially hazardous and explosive gases. Manufactured from galvanised steel sheet and provided with an inspection cover that can be removed to access the motor/ impeller assembly without having to remove the complete fan casing from the ducting. All model incorporate direct-drive forward curved centrifugal impeller. Working temperature from -20 to 55 °C.

**Motors**

Available in 4 poles. Three-phase 4 pole motors, IP55, class F with PTC thermal protection. Electrical supply: Three phase 230/400V-50Hz.

**ATEX ILT**

Explosion proof versions in accordance with ATEX Directive, for 3 phase models. For ambient working temperatures from -20°C to +55°C.

- ATEX Increased safety - Gas  
 Ⓜ II 2G Exe II T3 Gb  
 EC: LOM II ATEX 2026 X



**Easy to install**  
 Standard rectangular flanges to ease the Installation.



**IP55 remote terminal box**  
 To ease installation and maintenance.



**Inspection cover**  
 To facilitate maintenance.



**Specific applications**

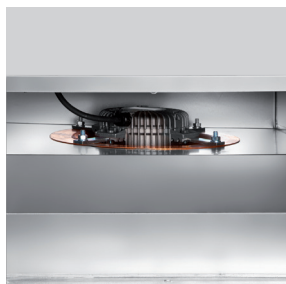

**Non-sparking construction**  
 Non-sparking construction in copper.

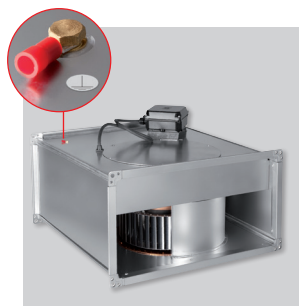

**Earth connection.**

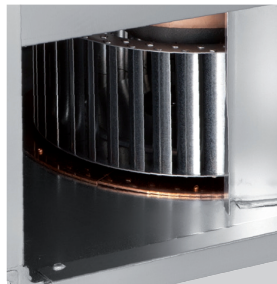

**ATEX mouthpiece**

## TECHNICAL CHARACTERISTICS

Before installation check that the product electrical characteristics listed on the data plate label (voltage, power, frequency, etc.) match those of the intended electrical supply.

Model	Nominal ducting dimensions	Speed (rpm)	Maximum absorbed power (W)	Maximum absorbed current (A)		Maximum airflow (m <sup>3</sup> /h)	Sound pressure level* (dB(A))		Weight (kg)
				230 V	400 V		Inlet	Outlet	
ILT/4-225 EX	500x250	1200	565	1,7	1	1.720	62	66	20
ILT/4-250 EX	500x300	1240	1150	3,3	1,9	2.610	67	70	25
ILT/4-285 EX	600x300	1200	1430	4	2,3	3.260	67	72	32
ILT/4-315 EX	600x350	1370	2300	8,5	4,9	4.000	72	77	42

\* Sound pressure level measured in free field condition at 1,5m, at the "A" working point of the performance curve.

\*\* Only with 230/400V motor.

## DIMENSIONS (mm)

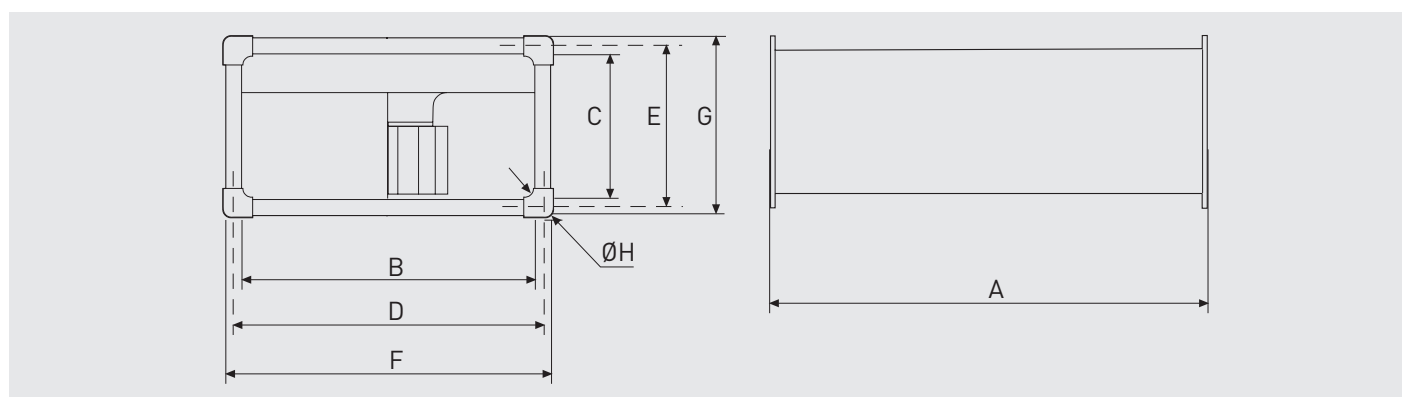

Model	A	B	C	D	E	F	G	Ø H
225	535	500	248	520	270	540	290	9
250	565	500	298	520	320	540	340	9
285	645	600	298	620	320	640	340	9
315	725	600	348	620	370	640	390	9

## PERFORMANCE CURVES

- $q_v$ : Airflow in  $m^3/h$  and  $m^3/s$ .
- $p_{sf}$ : Static pressure in mmWG and Pa.
- Dry air at 20°C and 760 mmHg.
- Performance data in accordance with ISO 5801 and AMCA 210-99 Standards.
- The sound power spectrum in dB (A), at the fan inlet, discharge and radiated at 3 working points of the performance curve [A: maximum volume].

Performance curves (A): obtained with auto-transformer (RMT).  
Performance curves (B): obtained with speed controllable by inverter.

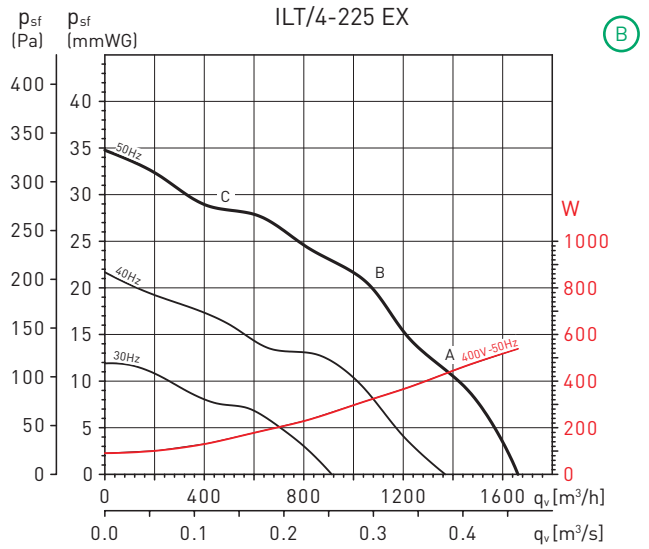
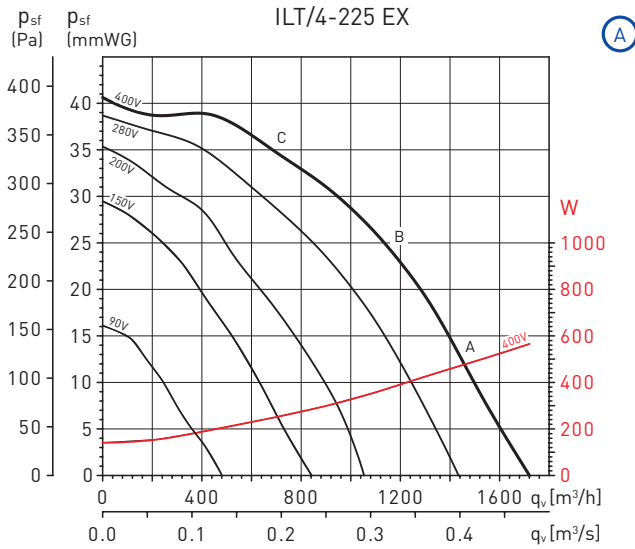

ILT/4-225 EX		63	125	250	500	1.000	2.000	4.000	8.000	LwA
Inlet	A	51	63	66	71	72	69	64	55	76
	B	48	60	63	68	69	66	61	52	73
	C	43	55	58	63	64	61	56	47	68
Outlet	A	48	63	66	72	77	74	72	65	81
	B	45	60	63	69	74	71	69	62	78
	C	41	56	59	65	70	67	65	58	74
Radiated	A	51	56	57	59	62	62	57	47	68
	B	48	53	54	56	59	59	54	44	65
	C	43	48	49	51	54	54	49	39	60

ILT/4-225 EX		63	125	250	500	1.000	2.000	4.000	8.000	LwA
Inlet	A	50	62	65	70	71	68	63	54	75
	B	46	58	61	66	67	64	59	50	71
	C	42	54	57	62	63	60	55	46	67
Outlet	A	46	61	64	70	75	72	70	63	79
	B	42	57	60	66	71	68	66	59	75
	C	38	53	56	62	67	64	62	55	71
Radiated	A	50	55	56	58	61	61	56	46	67
	B	46	51	52	54	57	57	52	42	63
	C	40	45	46	48	51	51	46	36	57

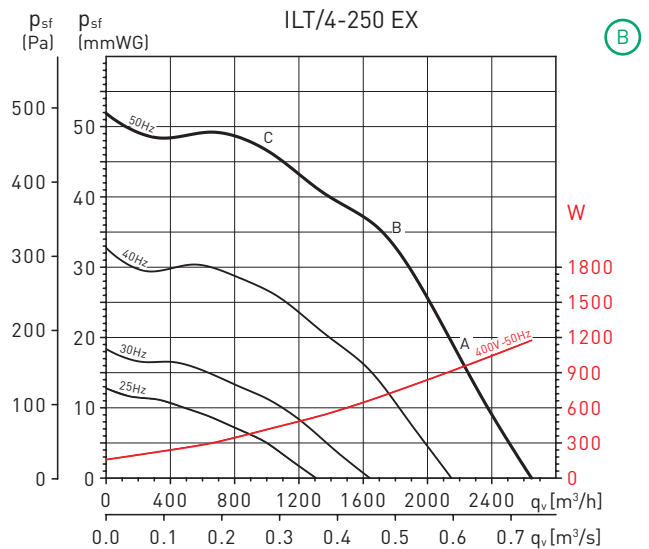
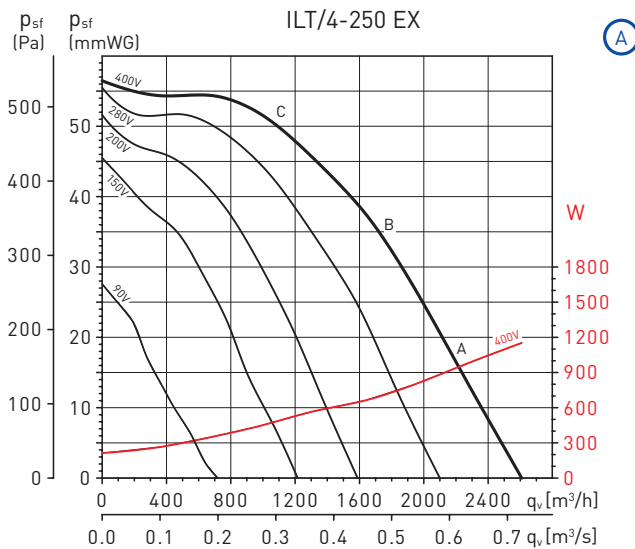

ILT/4-250 EX		63	125	250	500	1.000	2.000	4.000	8.000	LwA
Inlet	A	56	68	70	75	76	75	70	61	81
	B	53	65	67	72	73	72	67	58	78
	C	49	61	63	68	69	68	63	54	74
Outlet	A	52	67	69	77	80	79	76	69	85
	B	50	65	67	75	78	77	74	67	83
	C	47	62	64	72	75	74	71	64	80
Radiated	A	56	61	61	64	65	64	60	51	71
	B	53	58	58	61	62	61	57	48	68
	C	49	54	54	57	58	57	53	44	64

ILT/4-250 EX		63	125	250	500	1.000	2.000	4.000	8.000	LwA
Inlet	A	56	68	70	75	76	75	70	61	81
	B	53	65	67	72	73	72	67	58	78
	C	48	60	62	67	68	67	62	53	73
Outlet	A	52	67	69	77	80	79	76	69	85
	B	50	65	67	75	78	77	74	67	83
	C	46	61	63	71	74	73	70	63	79
Radiated	A	56	61	61	64	65	64	60	51	71
	B	53	58	58	61	62	61	57	48	68
	C	48	53	53	56	57	56	52	43	63

## PERFORMANCE CURVES

- $q_v$ : Airflow in  $m^3/h$  and  $m^3/s$ .
- $p_{sf}$ : Static pressure in mmWG and Pa.
- Dry air at 20°C and 760 mmHg.
- Performance data in accordance with ISO 5801 and AMCA 210-99 Standards.
- The sound power spectrum in dB (A), at the fan inlet, discharge and radiated at 3 working points of the performance curve (A: maximum volume).

Performance curves (A): obtained with auto-transformer (RMT).  
Performance curves (B): obtained with speed controllable by inverter.

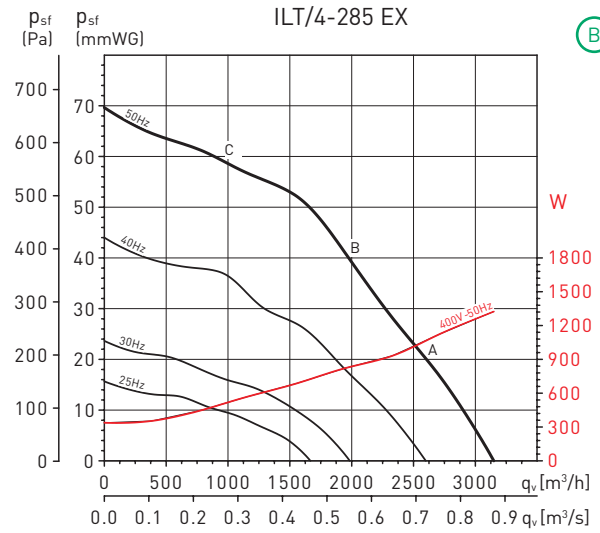
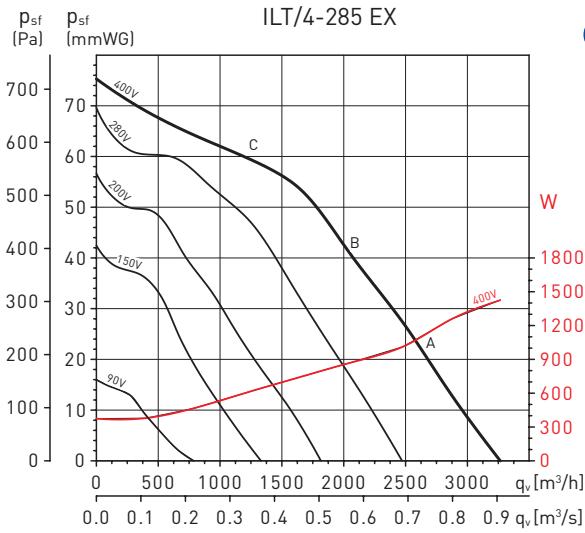

ILT/4-285 EX		63	125	250	500	1.000	2.000	4.000	8.000	LwA
Inlet	A	57	69	71	75	76	76	72	67	82
	B	58	70	72	76	77	77	73	68	83
	C	53	65	67	71	72	72	68	63	78
Outlet	A	54	69	71	80	82	81	78	71	87
	B	55	70	72	81	83	82	79	72	88
	C	51	66	68	77	79	78	75	68	84
Radiated	A	57	64	64	65	61	61	59	56	71
	B	58	65	65	66	62	62	60	57	72
	C	53	60	60	61	57	57	55	52	67

ILT/4-285 EX		63	125	250	500	1.000	2.000	4.000	8.000	LwA
Inlet	A	57	69	71	75	76	76	72	67	82
	B	57	69	71	75	76	76	72	67	82
	C	52	64	66	70	71	71	67	62	77
Outlet	A	54	69	71	80	82	81	78	71	87
	B	54	69	71	80	82	81	78	71	87
	C	50	65	67	76	78	77	74	67	83
Radiated	A	57	64	64	65	61	61	59	56	71
	B	57	64	64	65	61	61	59	56	71
	C	52	59	59	60	56	56	54	51	66

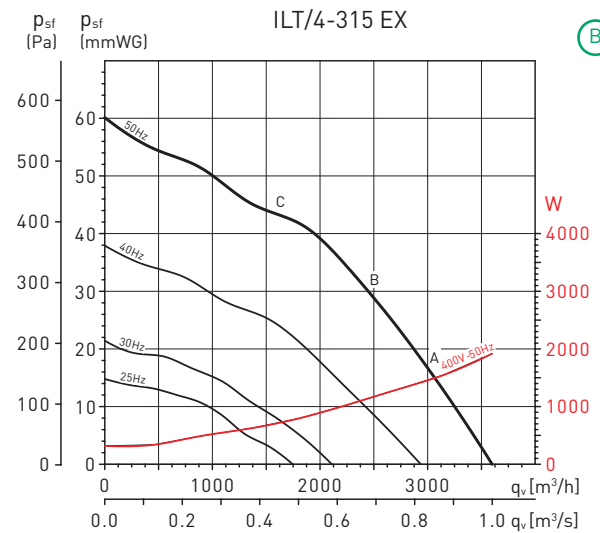
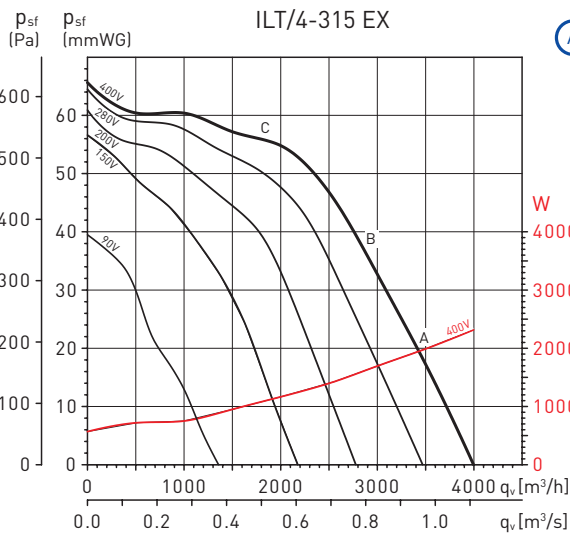

ILT/4-315 EX		63	125	250	500	1.000	2.000	4.000	8.000	LwA
Inlet	A	62	74	76	80	81	81	77	72	87
	B	59	71	73	77	78	78	74	69	84
	C	53	65	67	71	72	72	68	63	78
Outlet	A	59	74	76	85	87	86	83	76	92
	B	56	71	73	82	84	83	80	73	89
	C	51	66	68	77	79	78	75	68	84
Radiated	A	62	69	69	70	66	66	64	61	76
	B	59	66	66	67	63	63	61	58	73
	C	54	61	61	62	58	58	56	53	68

ILT/4-315 EX		63	125	250	500	1.000	2.000	4.000	8.000	LwA
Inlet	A	59	71	73	77	78	78	74	69	84
	B	55	67	69	73	74	74	70	65	80
	C	50	62	64	68	69	69	65	60	75
Outlet	A	56	71	73	82	84	83	80	73	89
	B	54	69	71	80	82	81	78	71	87
	C	48	63	65	74	76	75	72	65	81
Radiated	A	59	66	66	67	63	63	61	58	73
	B	55	62	62	63	59	59	57	54	69
	C	51	58	58	59	55	55	53	50	65

**SPECIFIC ACCESSORIES**

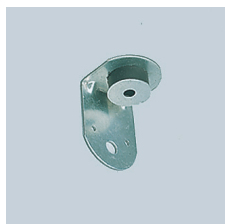

**ISA**  
 Anti-vibration mounting.  
 1 ISA = 4 supports.



**IBR**  
 Rectangular duct flange.



**DEF**  
 Rectangular defense guard.



**IAE EX**  
 Rectangular flexible connector.

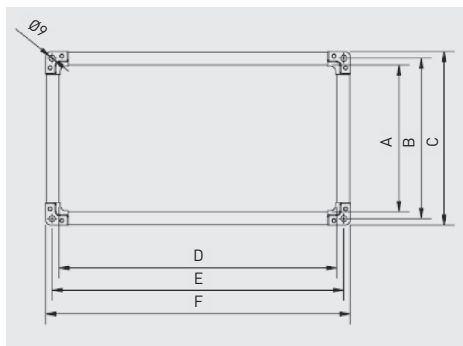

Model	A	B	C	D	E	F
IAE EX - 225	248	270	290	500	520	540
IAE EX - 250	298	320	340	500	520	540
IAE EX - 285	298	320	340	600	620	640
IAE EX - 315	348	370	390	600	620	640

**ELECTRICAL ACCESSORIES (INSTALLED OUTSIDE THE ATEX AREA)**

NOTE: The following accessories are certified for use with the equipment. For that reason, they cannot be substituted with any other type or brand of accessory.



**Protection system for the motor MSK EX**  
 Set comprising a protection relay in combination with a circuit breaker.  
 For 400V three-phase motors with PTC.

For more information see Electrical accessories.

**Connection diagrams of the electrical accessories.**

